

# PANTOGRAPH

Type **SPL**

RAIL VEHICLES



# GENERAL INFORMATION

**SPL** pantograph is the ideal solution for manufacturers and operators of tramways and light rail vehicles, looking for an efficient and reliable current collecting device.

With its wide working range (500 – 3,300 mm above roof) and record flatness (300mm above roof), Sécheron SPL pantograph achieves high performances with constrained weight and great stiffness of design. Its unique panhead suspension system offers SPL pantograph an excellent dynamic behaviour, with

great benefits to the contact reliability between the pantograph and overhead lines, as well as to the carbon strips life time. SPL are thoroughly tested and surpass standard requirements, making them fully compliant with EN 50126-2/IEC 60494-2 and EN/IEC 61373.

In commercial operation on different tramway networks throughout Europe, SPL pantograph has demonstrated its robustness and reliability in different operational and climatic conditions.

## APPLICATIONS

### SAFETY FUNCTIONS

- ① Pantograph
- ② Knife switch
- ③ DC surge arrester
- ④ DC circuit breaker

**SPL**  
**SED18.15**  
**UR**

### SWITCHING FUNCTIONS

- ⑦ Line contactor
- ⑧ Charging contactor
- ⑨ Power contactor module
- ⑩ Motor isolating contactor

**BMS**  
**PCC, HS,**  
**PCM**  
**BMS**

### MEASUREMENT FUNCTIONS

- ④ Current sensor
- ⑤ Voltage sensor

### Tramway and LRV vehicles

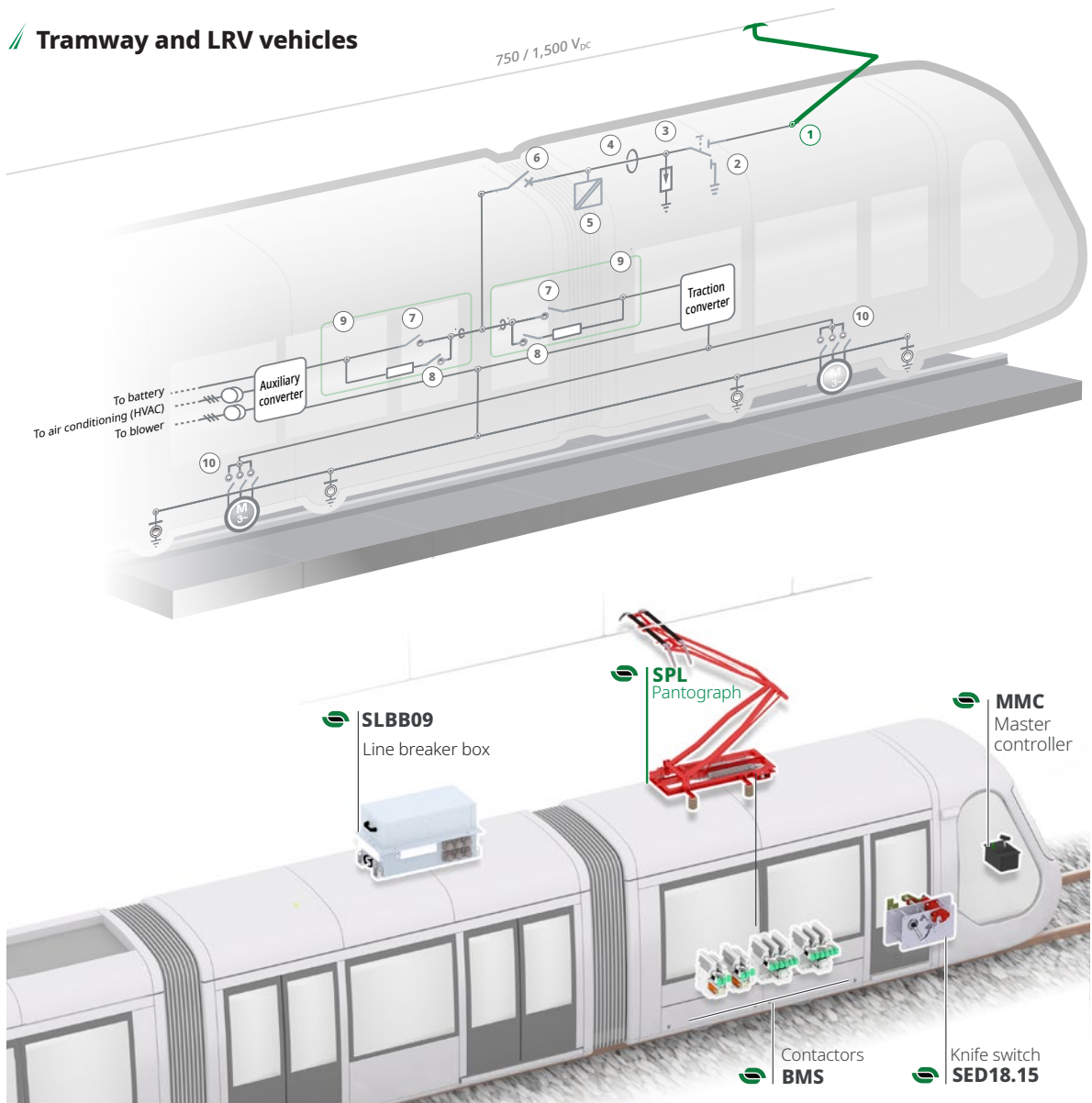

## PRODUCT DESCRIPTION

A simple design, made of 4 main elements, guarantees the pantograph reliable operation for operators:

1. The base frame made of a steel welded lightweight profile, enables fixing the pantograph on the vehicle through four insulators. The frame houses all of the other parts (lower and upper arms assembly, damper linear actuator, high and low-voltage electrical interfaces).
2. The lower and upper arms are made of welded thin steel tubes, housing insulated maintenance free bearings. Two unstrained stainless steel rods insure the rigidity. Flexible braids allow safe electrical connections.
3. The panhead, installed on a leaf spring suspension system, is designed to allow free movements in all necessary directions to always guarantee the electrical continuity between the contact strips and the overhead line.
4. The drive unit combines the linear actuator with the main spring to operate the pantograph.

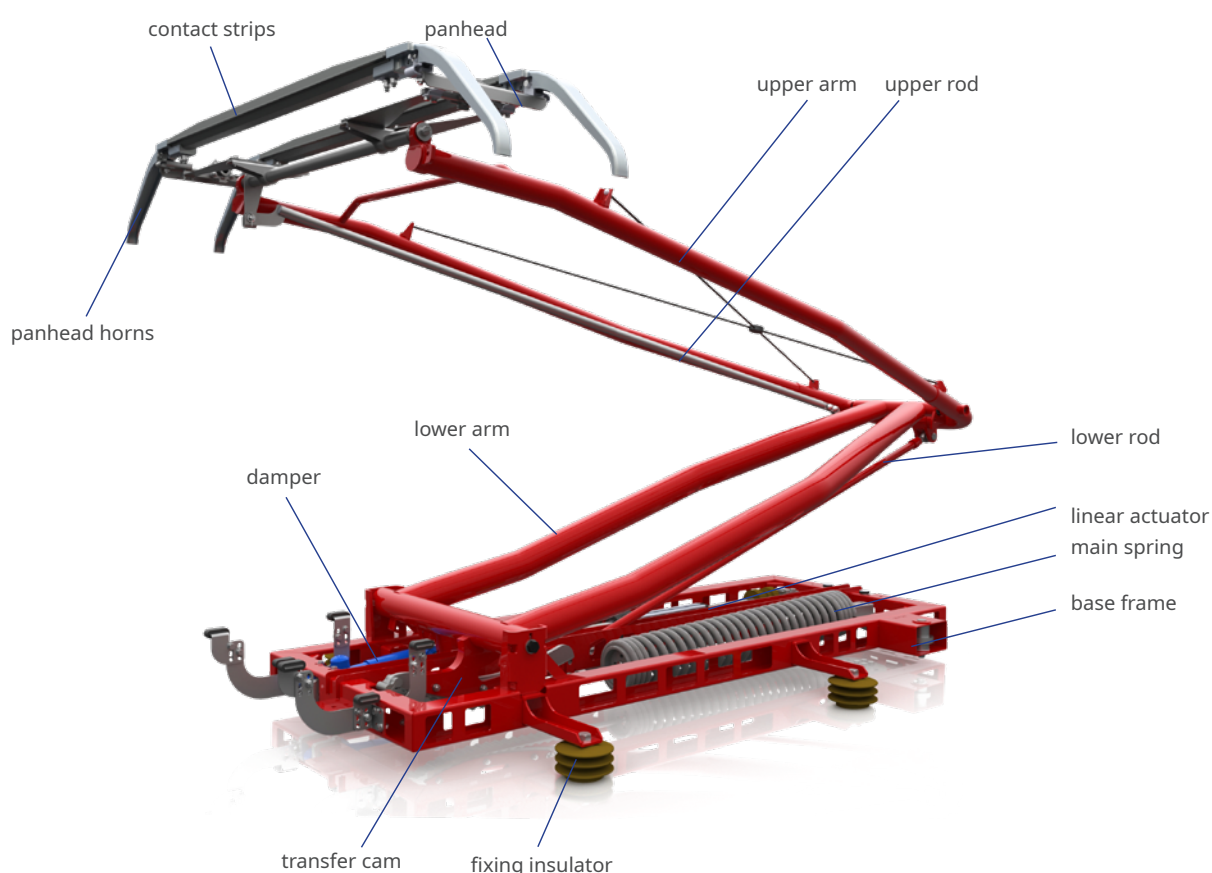

## MAIN BENEFITS

- ✓ Unique panhead suspension system offering excellent dynamic performance.
- ✓ Electric raising & lowering.
- ✓ Very flat design – allows the use of an intermediate frame to match roof fixation points for retrofit projects.
- ✓ Automatic Dropping Device to limit damages due to abnormal shocks on panhead.
- ✓ In-house key technologies (high-voltage, FEM & Multibody simulations, welding, dynamic test-bench, material & surface treatment, ...).
- ✓ Extensive factory testing for a high reliability in service.
- ✓ Very low maintenance requirements.
- ✓ Worldwide service point network.

# DATA FOR PRODUCT SELECTION

	Symbol	Unit	SPL26 / SPL30
<b>MAIN HIGH VOLTAGE CIRCUIT</b>			
<b>Mechanical characteristics</b>			
Maximal running speed	$V_{MAX}$	[km/h]	80 (100 in option)
Static contact force	$F_{st}$	[N]	60 - 110
Maximum weight (without insulators)		[kg]	158 ±5
<b>Main high voltage circuit</b>			
Nominal voltage of the traction system	$U_n$	[V <sub>DC</sub> ]	600; 750; 1,500
Highest permanent voltage	$U_{max1}$	[V <sub>DC</sub> ]	1,800
Rated insulation voltage (HV parts against LV parts)	$U_{Nm}$	[V <sub>DC</sub> ]	2,300
Rated impulse voltage	$U_{Ni}$	[kV]	18
Rated operational current fo standstill	$I_{es}$	[A]	≤ 200
Rated operational current fo running <sup>(1)</sup>	$I_{er}$	[A]	≤ 1,000
Overload capacity for running	$I_{adm}$	[A]	≤ 1,300
Overvoltage category			OV4
<sup>(1)</sup> at $T_{amb} = 40^\circ\text{C}$ for 10 s.			
<b>LOW VOLTAGE AUXILIARY CIRCUIT</b>			
<b>Control circuit</b>			
Type of the actuator			Electric
Nominal voltage	$U_n$	[V <sub>DC</sub> ]	24
Supply voltage limits <sup>(2)</sup>			[0.7 - 1.25] $U_n$
Nominal raising power <sup>(3)</sup>	$P_r$	[W]/[s]	260/20
Holding nominal power <sup>(3)</sup>	$P_h$	[W]	0
Nominal lowering power <sup>(3)</sup>	$P_l$	[W]/[s]	260/20
Mechanical raising time <sup>(4)</sup>	$t_r$	[s]	≤ 10
Mechanical lowering time <sup>(4)</sup>	$t_l$	[s]	≤ 10
Rated power frequency withstand voltage - control circuit-earth	$U_a$	[V]/[Hz]/[s]	750/50/10
<sup>(2)</sup> at $-25^\circ\text{C} < T_a < +40^\circ\text{C}$ . • <sup>(3)</sup> At $20^\circ\text{C}$ • <sup>(4)</sup> Typical at $U_n$ and $T_{amb} = 20^\circ\text{C}$			
<b>Auxiliary switches of actuator</b>			
Auxiliary contacts	N		2
Type			Changeover (CO)
- Let-through current <sup>(5)</sup>		[mA]	150
- Switching power		[W]	3.6
Mechanical durability	n		10 <sup>6</sup>
<b>Low voltage interface</b>			
Type of connection			1 connector Harting HAN 16E
<sup>(5)</sup> at 24 V <sub>DC</sub>			
<b>OPERATING CONDITIONS</b>			
Working ambient temperature outdoors	$T_{amb}$	[°C]	-25°C to +40°C
Altitude	h		≤ 2,000
Humidity at 40°C			≤ 95%
Shocks and mechanical vibrations (according to IEC61373:2010)			Category 1 Class A
Pollution degree			PD4
<b>MOUNTING</b>			
Installation			Outdoor
Applications			Rolling stock, on the vehicle roof
Monting position			Horizontal
Fixation			On the roof frame or on the roof fixing supports
HV Electrical connections			Cu cables or bus-bars

# PRODUCT INTEGRATION

## MAIN DIMENSIONS

All dimensions and characteristics in this brochure are valid for standard tramway and light rail vehicles pantographs.

Shall your vehicle-pantograph interfaces be different, please contact Sécheron.

### SPL26 / SPL30

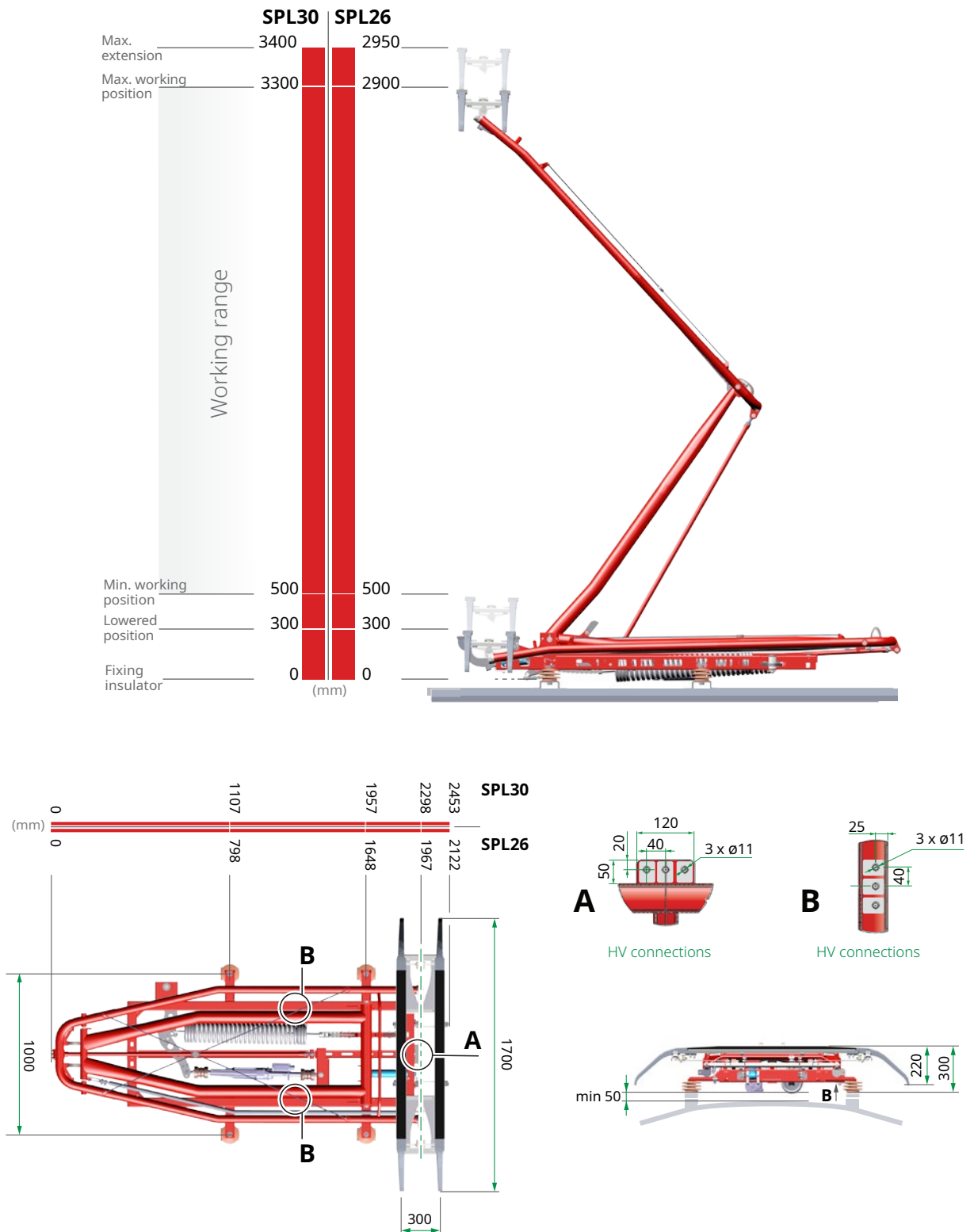

# TECHNICAL DATA

## TYPICAL SPL PANTOGRAPH CONTROL DIAGRAM

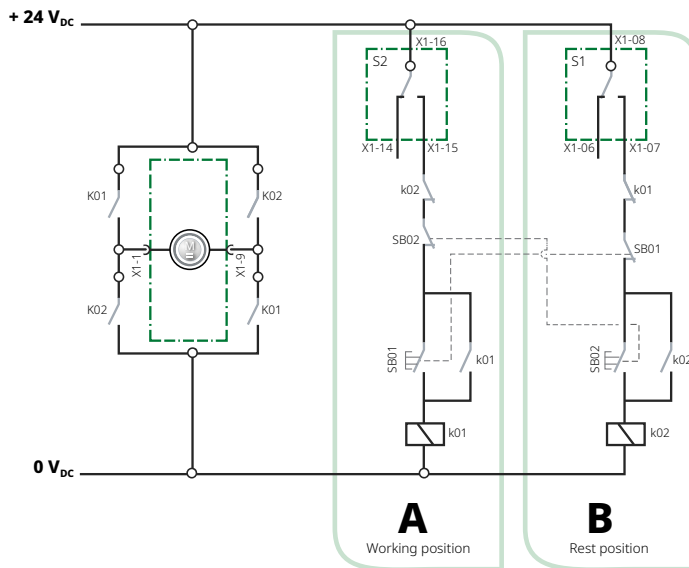

### Legend

- Sécheron scope (Pantograph)
- A** Diagram of the working position
- B** Diagram of the rest position
- K01, K02 Relays
- SB1 Push button to raise the pantograph
- SB2 Push button to lower the pantograph

## LOW VOLTAGE CONNECTOR WIRING DIAGRAM

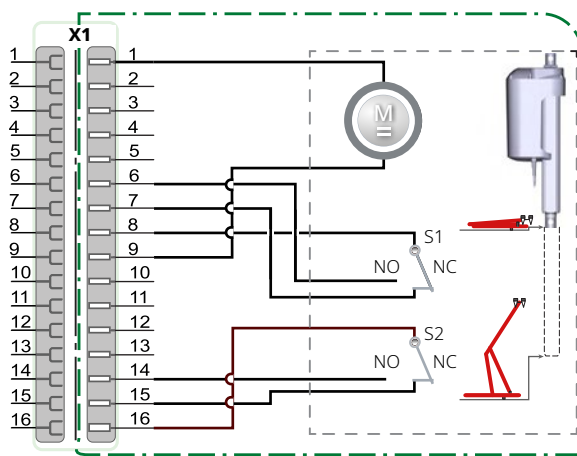

### Legend

- X1**: pantograph Harting HAN16B connector 16 poles
- S1**: pantograph position detection switch (pantograph in low position)
- S2**: pantograph position detection switch (pantograph in raised position)

## FUNCTIONING DIAGRAM

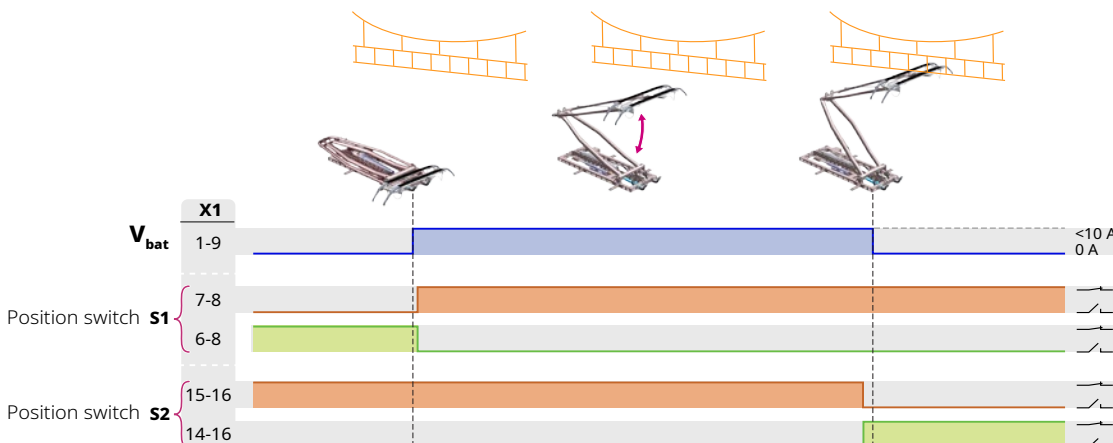

# OPTIONS (SUBJECT TO ADDITIONAL COSTS)

## MANUAL OPERATIONS DEVICE (MOD)

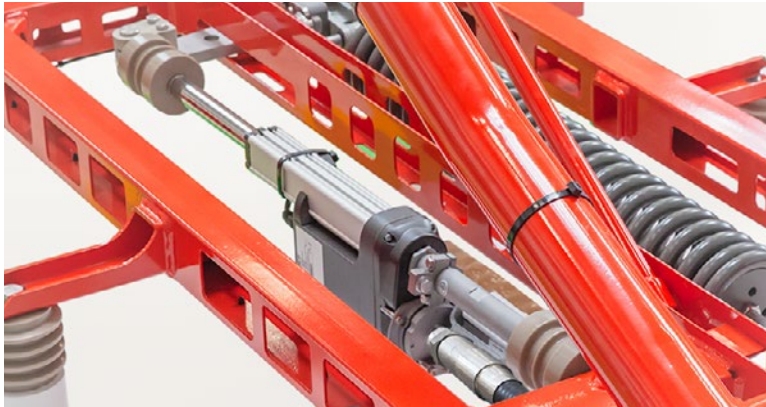

Connection to linear actuator

Would the auxiliary power supply be unavailable, the pantograph can be manually operated through a flexible shaft linked to the linear actuator and accessible from inside the vehicle.

## AUTOMATIC DROPPING DEVICE (ADD)

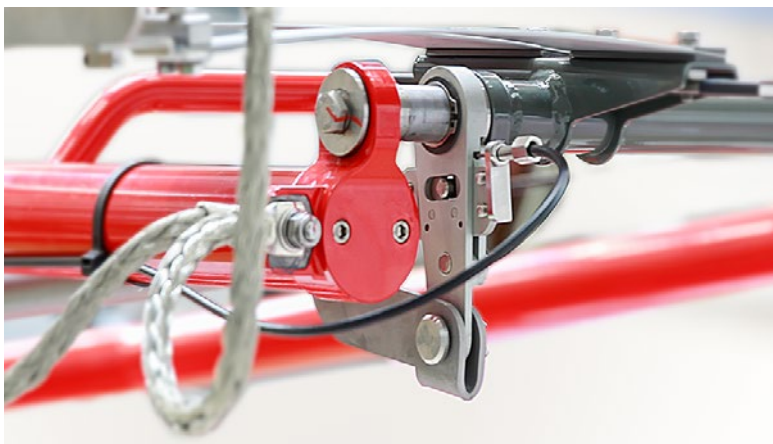

Trigger device (panhead)

To limit damages caused by abnormal shocks applied to the pantograph's panhead during operation, an Automatic Dropping Device can be mounted on the pantograph for a fast-drop action.

### MAIN FEATURES

- Mechanical ADD device for panhead disconnection from overhead line in case of heavy shock
- Fast panhead disconnection, less than 1 sec.
- Fast Pantograph lowering, around 3 sec.
- ADD activation in both running directions

## MAIN BENEFITS

- ✓ Protect and prevents consequential damages on the overhead line
- ✓ Limits damages on the pantograph

# DESIGNATION CODE FOR ORDERING

- Be sure to establish the designation code from the latest version of our brochure by downloading it from the website: [www.secheron.com](http://www.secheron.com).
- For technical reasons some variants and options indicated in the designation code might not be combined, therefore validate your configuration with Sécheron before ordering.
- For other configurations not described in the brochure, please contact Sécheron.

## DESIGNATION CODE

Line	Description		Designation		Customer's choice
			Standard	Options	
10	Product type	SPL	SPL		SPL
11	Max. working extension above roof	SPL30: 3,300 mm SPL26: 2,900 mm	•		
12	Rated operational voltage	900 V <sub>DC</sub> 1,800 V <sub>DC</sub>	•		
13	Maximum running current	1,000 A 1,500 A	•	•	
14	Maximum standstill current	100 A 150 A 200 A Please specify optional maximum standstill current below	•	• • •	
15	High voltage interface	3 × M12 3 × M10 3 × M16	•	• •	
16	HV interface Location	Below Panhead/Both sides	•		X
17	Control voltage (electric drive)	24 V <sub>DC</sub>	•		
18	Color	Dark grey (RAL7011) Please specify optional RAL color code below	•	•	
19	Manual operation device (MOD)	No Yes	•	•	
20	- Length of MOD flexible shaft	1.5 m Optional length 2.0 & 2.5 m	•	•	
21	- Spare digit	Not applicable	•		X
22	Automatic dropping device (ADD)	No Yes	•	•	

## PANHEAD CHARACTERISTICS

A: total width: \_\_\_\_\_ mm

B: distance between strips center lines: \_\_\_\_\_ mm

C: strip width: \_\_\_\_\_ mm

D: strip length: \_\_\_\_\_ mm

Horn material  Aluminium  Insulating material  
Strip material  Carbon  Metal impregnated carbon  Copper

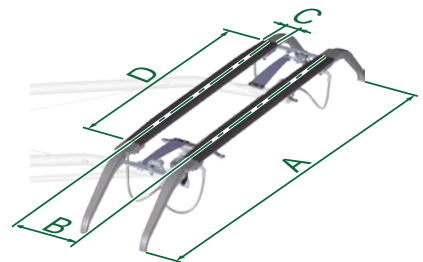

## CUSTOMER DATA

Maximum standstill current: \_\_\_\_\_ A

Length of the MOD flexible shaft: \_\_\_\_\_ mm ± \_\_\_\_\_ mm Color option: RAL \_\_\_\_\_



📍 Sécheron SA  
Rue du Pré-Bouvier 25  
1242 Satigny - Geneva  
CH-Switzerland

[www.secheron.com](http://www.secheron.com)  
Tel: +41 22 739 41 11  
Fax: +41 22 739 48 11  
ess@secheron.com